

**AUTO ROTARY PRESS for VITRIFIED WHEELS** D250 | 8 Station | Model SRPV15250S08

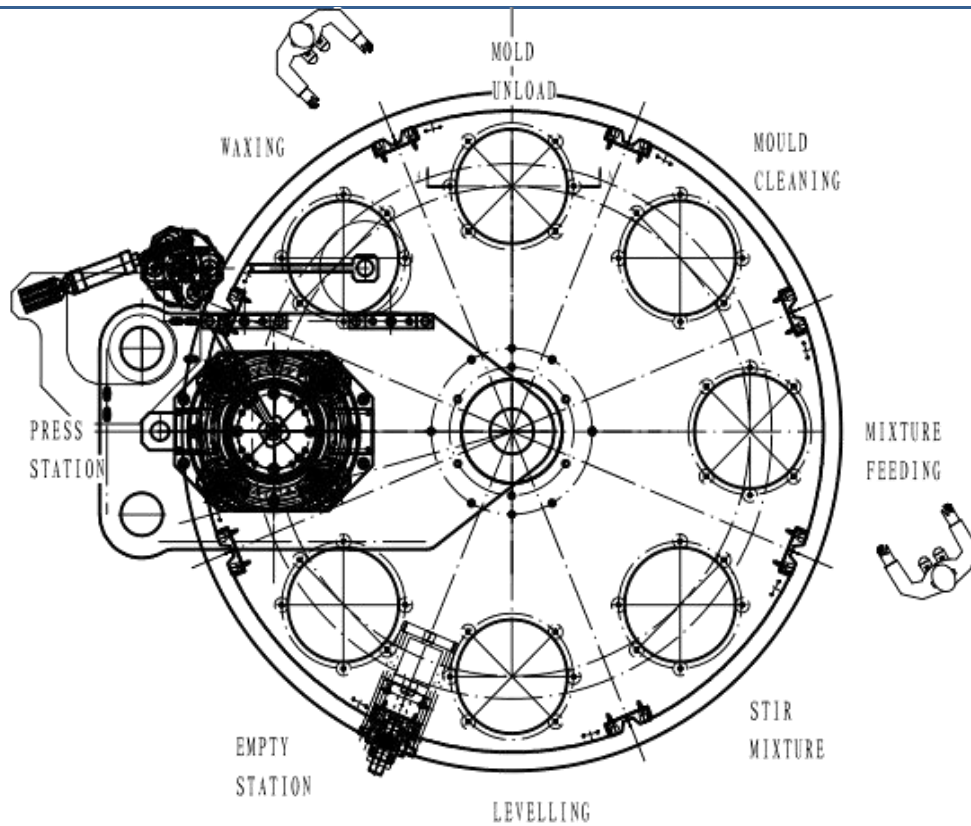

- Exterior Dimensions: 2000 x 2200 x 2400mm
- Weight: 10MT
- Voltage: 380V/50Hz or On Request
- Main Cylinder Press Power: 200T
- Mould Unload Hydraulic Cylinder: 30KN
- Double-Side Press: Lift-Pneu Cylinder 7KN
- Station: 8
- Installed Power: 23Kw
- Control system: PLC
- Mix Feeding: auto/manual
- Number of Operator: 2-3
- Cycle Time: 18-22s/wheel ; 180pc/hour
- Diameter of Wheel:  $\Phi$ 150-250mm
- Thickness of Wheel: 10-50mm
- Core Diameter: 32mm
- Type of Wheel: T41



Foot Print: 7000 x 6000mm

**Packing:**

Wooden case

Other size vitrified grinding wheel production machines are available.

If you have any questions about this machine, please contact  
Mr.Zhang, E-mail: [info@skdengineering.cn](mailto:info@skdengineering.cn)